

GLASSWALL SPECIFICATIONS

Series GL2 Paired, Glass Panels

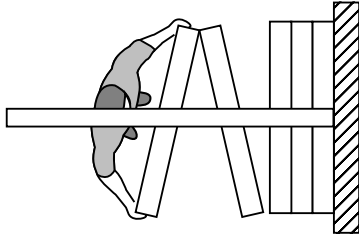

Top Supported
Center Stack
Paired Panels
Manually Operated
Maximum Opening Height: 10' 5"[3.2m]
Maximum Opening Width: Unlimited

PRODUCT OVERVIEW:

Select for Special Needs: Use in areas that you wish to divide with a physical, but not a visual, barrier and where sound control is not a requirement.

Standard Features: Panels are of glass, mechanically fastened to top and bottom horizontal rails. The support rails are of anodized aluminum.

Paired Panels: Select for wall-to-wall space division. Panels are hinged in pairs allowing fast setup. They may be stacked at either or both ends of the track or in a "pocket".

How to Obtain: Hufcor partitions are sold, installed, and serviced by factory-trained local authorized Distributors in the United States and by Licensees and Distributors outside the U.S.A.

Delivery: Panels are custom built for your specific project. Lead times vary due to seasonal fluctuations. Check with your Distributor for the current schedule.

Warranty: Track, carriers, and horizontal rails are guaranteed for **one year** against defects in material and workmanship. The glass is not included in this warranty.

"Standard" Product Features and Benefits:

Look for these features when comparing similar products.

- Feature:** Interlocking bottom rails
Benefit: Ensures flat setup of the partition.
- Feature:** Floorbolts must be set before next panel pair can be positioned
Benefit: Ensures that floorbolts are set, that the panel is plumb, and securely locked in place.
- Feature:** Mechanical pins hold glass through holes in glass (instead of friction)
Benefit: Provides a positive hold and ensures that the glass cannot slip from the top rail.

(Important note: there is a 1/4-1/2" [6-12] gap between panel joints to prevent glass from touching during panel setup. Size of gap varies due to glass tolerances.)



The standard product may be modified to fit individual job site requirements. Contact your Hufcor representative for assistance.

GENERAL SPECIFICATIONS/GLASSWALL

GL2 Paired, Glass Partitions

PART 1 - GENERAL

1.01 DESCRIPTION

A. General

1. Furnish and install operable glass partitions and suspension system. Provide all labor, materials, tools, equipment, and services for glass operable walls in accordance with provisions of contract documents.

1.02 RELATED WORK BY OTHERS

- A. Preparation of opening will be by General Contractor. Any deviation of site conditions contrary to approved shop drawings must be called to the attention of the architect.
- B. All header, blocking, support structures, jambs, and track enclosures, as required in 1.04 Quality Assurance.
- C. Prepunching of support structure in accordance with approved shop drawings.
- D. Paint or otherwise finishing all trim and other materials adjoining head and jamb of the partitions.

1.03 SUBMITTALS

- A. Complete shop drawings are to be provided prior to fabrication indicating construction and installation details. Shop drawings must be submitted within 60 days after receipt of signed contract.

1.04 QUALITY ASSURANCE

- A. Preparation of the opening shall conform to the criteria set forth per ASTM E557 Standard Practice for Architectural Application and Installation of Operable Partitions..
- B. Glass shall be clear tempered per ASTM C1048-97b.

1.05 PRODUCT DELIVERY, STORAGE, AND HANDLING

- A. Proper storage of partitions before installation and continued protection during and after installation will be the responsibility of the General Contractor.

- 1.06 WARRANTY. Track, carriers, and horizontal rails shall be guaranteed for one year against defects in material and workmanship. The glass is not included in this warranty.

PART 2 - PRODUCTS

2.01 ACCEPTABLE MANUFACTURERS

- A. Upon compliance with all of the criteria specified in this section, Manufacturers wishing to bid products similar to the product specified must submit to the architect 10 days prior to bidding complete data in support of compliance and a list of three past installations of products similar to those listed. The submitting manufacturer guarantees the proposed substituted product complies with the product specified and as detailed on the drawings.

2.02 MATERIALS

- A. Product to be top supported, center stacked, Series GL2 paired glass panels as manufactured by Hufcor.
 1. Panels shall be nominally 1-5/8" [40] thick and to 48" [1219] in width.
 2. Glass shall be mechanically attached to top and bottom rails and not rely on friction and/or adhesives.
 3. All glass edges shall be polished and glass panel faces shall be a choice of
 - a. 1/2" [12] fully tempered glass
 - b. 1/2" [12] laminated glass.
 - c. 1/2" satiny translucent acid washed, full height, one side only
 - d. Optional (factory approval required):
 - Acrylic
 - Custom glass
 4. Top and bottom horizontal rail shall be anodized aluminum and incorporate brush light seals.
 5. Glass faces shall have no vertical trim. (Important note: there is a 1/4-1/2" [6-12] gap between panel joints to prevent glass from touching during panel setup. Size of gap varies due to glass tolerances.)
Optional upgrade: Glass faces shall have vertical trim of clear anodized aluminum.
 6. Each panel contains a footbolt which is extended into a floor mounted receiver to stabilize and secure each panel in the opening.

- B. Weight of the panels shall be approximately 7.4 lbs. per sq. ft. for 1/2" [12] glass.

C. Suspension system:

1. Track shall be of clear anodized architectural grade extruded aluminum alloy 6063-T6. Track design shall provide integral support for adjoining ceiling, soffit, or plenum sound barrier. Track shall be connected to the structural support by min. 3/8" [10] dia. threaded steel hanger rods. Guide rails and/or track sweep seals shall not be required.
 - a. Each panel shall be supported by one 4-wheeled carrier. Wheels to be of hardened steel ball bearings encased with molded polymer tires.
2. Option (available for select layouts-contact your Hufcor representative): The panels shall be supported by the Unispan pre-engineered truss and post system fabricated of steel and aluminum. Unispan is attached to the building structure for lateral support only. The load of the truss and partition is supported by end columns and the system transfers the weight to the floor.

D. Finishes

1. Horizontal rail color shall be (**select one**):
 - a. Clear anodized (standard)
 - b. Medium Bronze anodized (optional upgrade)
 - c. Dark Bronze anodized (optional upgrade)
 - d. Stainless steel clad (optional upgrade)
 - (1) Polished
 - (2) Brushed
 - #4 brushed
 - #7 brushed
 - e. Custom painted (optional upgrade)
 - f. Powder coated (optional upgrade)
2. Aluminum track shall be clear anodized
 - a. Optional upgrade:
 - (1) custom anodized
 - (2) custom powder coated

E. Available Accessories/Options

1. Pivot panel closure
 - a. Low profile handle (standard)
 - b. Vertical tube handle with push/pull handle one or both sides(optional)
 - c. Vertical tube handle with optional tube push bar, one side
2. Locks
 - a. Thumb turn floor lock
 - b. Keyed floor lock
3. Glass etching
 - a. Fully etched and sealed
 - b. Custom patterns

2.03 OPERATION

- A. Panels shall be manually moved from the storage area, unfolded, positioned in the opening, and floorbolts set.
- B. Final partition closure to be by (select one):
 1. Pivot panel
 2. Overlapping the opening
 3. End at wall
- C. Stack/Store Panels
 1. Retract footbolts, fold, and move to storage area. Panels may be stored at either or both ends of the track or in a pocket.

PART 3 - EXECUTION

- A. Installation. The complete installation of the glass wall system shall be by an authorized factory-trained installer and be in strict accordance with the approved shop drawings and manufacturer's standard printed specifications, instructions, and recommendations.
- B. Cleaning
 1. All track and panel surfaces shall be wiped clean and free of handprints, grease, and soil.
 2. Optional specialty glass requires special cleaning per instructions provided.
 3. Cartoning and other installation debris shall be removed to onsite waste collection area.
- C. Training
 1. Installer shall demonstrate proper operation and maintenance procedures to owner's representative.
 2. Owners manuals shall be provided to owner's representative.



VERTICAL SECTION

Shown with Type 38 Aluminum track. Standard for weights to 400 lbs. [182 kg]. Type 40 track system to be used for weights exceeding 400 lbs.

Type 40 Aluminum track.
Standard for weights exceeding 400 lbs. [182 kg].
Optional for panel weights under 400 lbs.

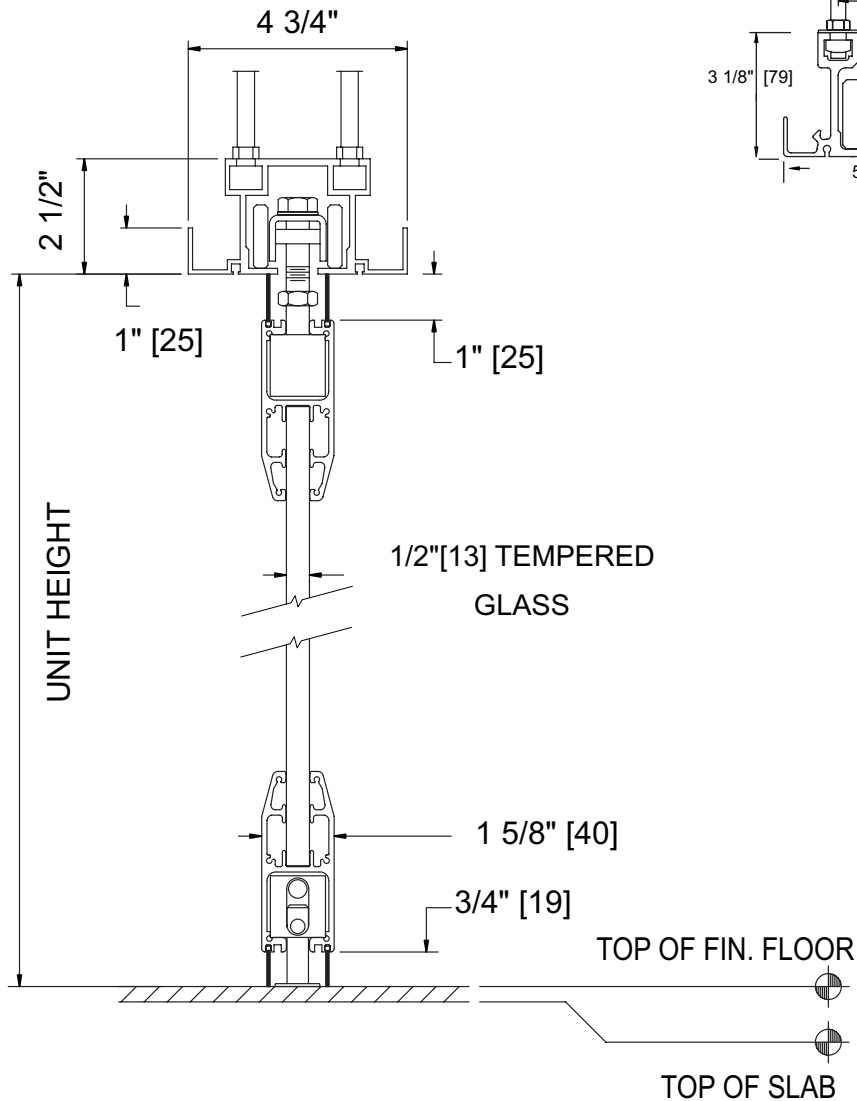

(Important note: there is a 1/4-1/2" [6-12] gap between panel joints to prevent glass from touching during panel setup. Size of gap varies due to glass tolerances.)

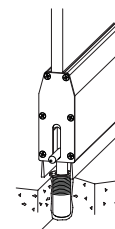

Footbolt engages in floor receptacle to ensure panel-to-panel alignment and stability.

No Scale

Paired, Operable Glass Partitions (cont'd)

Horizontal Section with Pivot Panel Closure

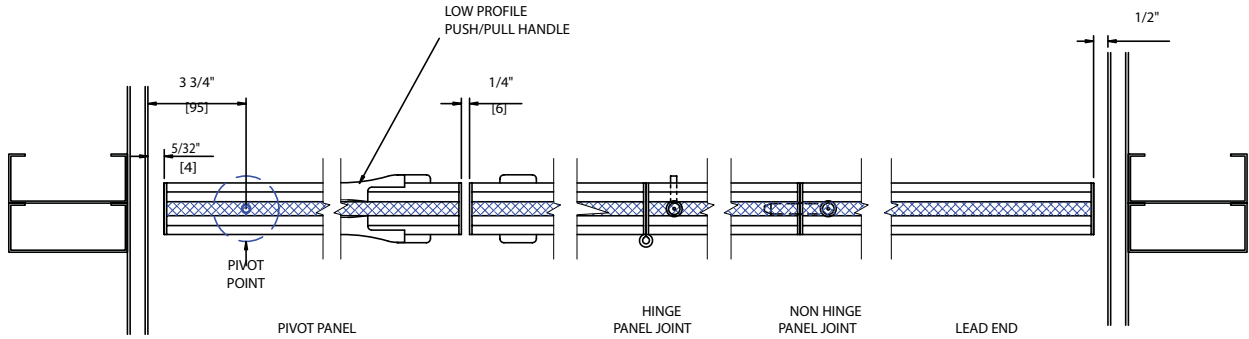

(Important note: there is a 1/4-1/2" [6-12] gap between panel joints to prevent glass from touching during panel setup. Size of gap varies due to glass tolerances.)

Horizontal Section without Pivot Panel Closure

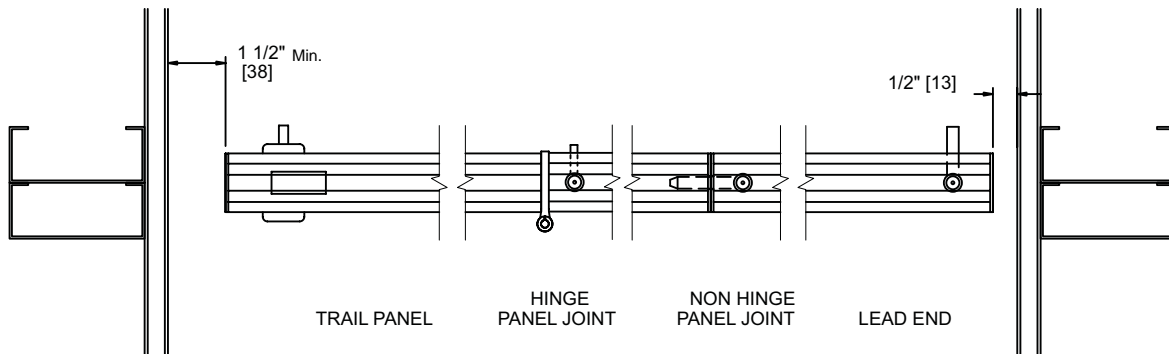

(Important note: there is a 1/4-1/2" [6-12] gap between panel joints to prevent glass from touching during panel setup. Size of gap varies due to glass tolerances.)

Paired, Operable Glass Partitions

Wall-to-Wall Opening. No pivot closure panel, no handle

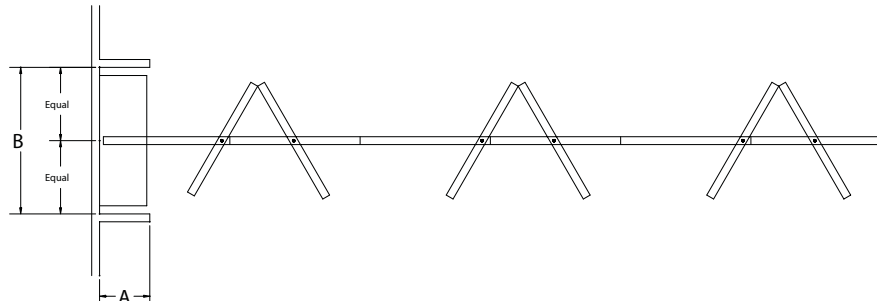

- A. Stack Depth:
 with Type 38 Track:
 3" [76.2] per panel + 2" [51]
 3" [76.2] per panel + 3-1/4" [83] with the push/pull handle.
 with Type 40 Track:
 4" [95] per panel + 2" [51]
 4" [95] per panel + 3-1/4" [83] with the push/pull handle.
- B. Stack Width:
 Panel width + 4" [101] finger clearance

Wall-to-Wall Opening with Stacking at Both Ends

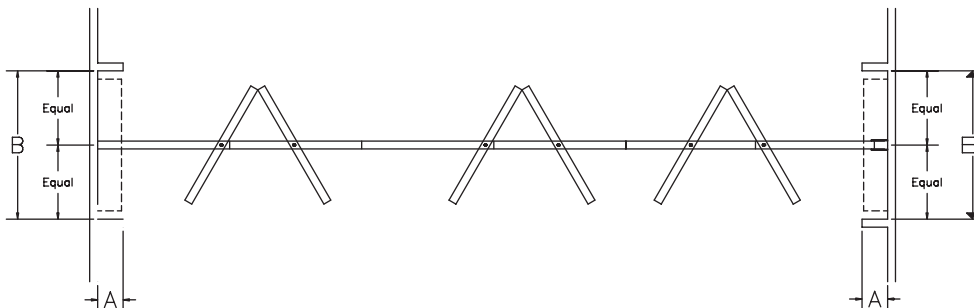

- A. Stack Depth:
 with Type 38 Track:
 3" [76.2] per panel + 4" [101] with low profile handle
 3" [76.2] per panel + 7" [178] with optional push/pull handle.
 with Type 40 Track:
 4" [95] per panel + 5" [127] with low profile handle
 4" [95] per panel + 7" [178] with optional push/pull handle.
- B. Stack Width:
 Pivot panel width - 3-3/4" [95] + one-half panel width + 4" [101] hand clearance

(Important note: there is a 1/4-1/2" [6-12] gap between panel joints to prevent glass from touching during panel setup. Size of gap varies due to glass tolerances.)

ELEVATION

Wall to Wall Opening with Pivot Panel Closure & Push/Pull Handle with Optional Push Bar

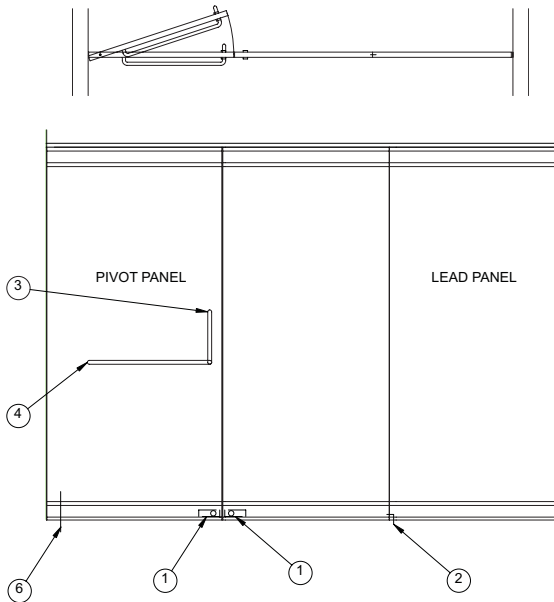

Wall to Wall Opening with Pivot Panel Closure & Low Profile handle

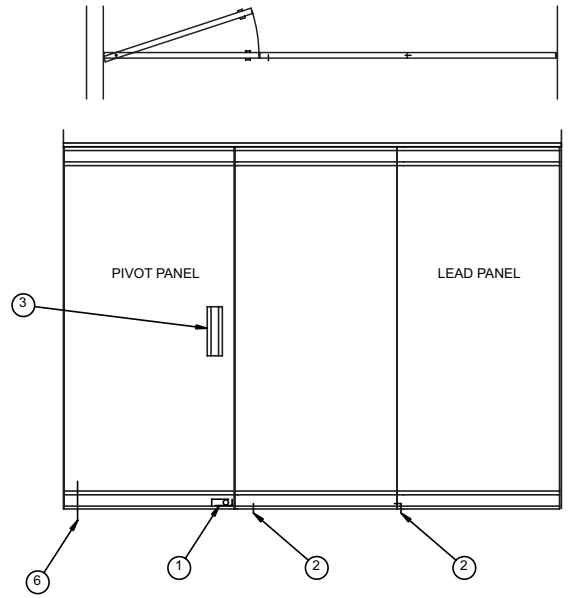

Wall to Wall Opening With No Pivot Closure: No Handle

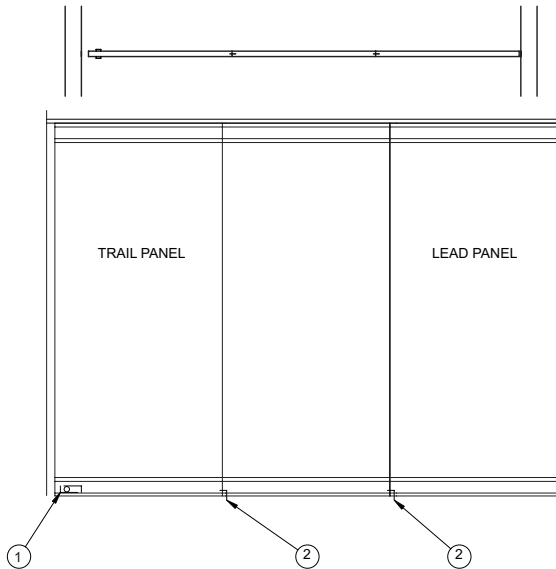

Wall to Wall Opening Without Pivot Closure: with Handle

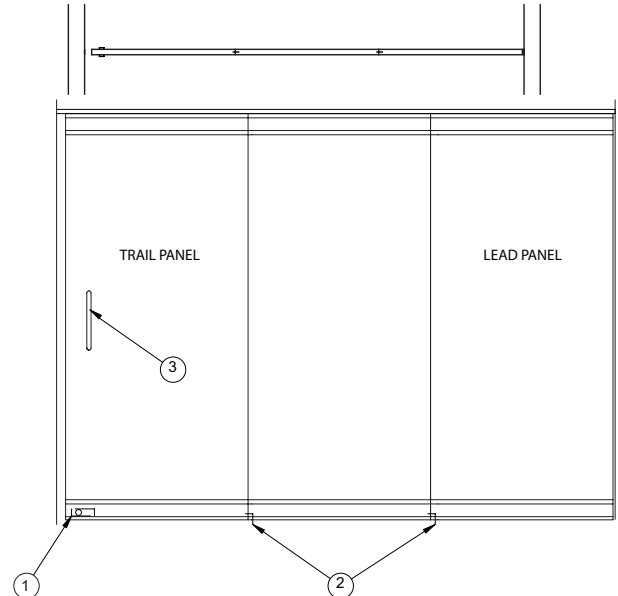

(Important note: there is a 1/4-1/2" [6-12] gap between panel joints to prevent glass from touching during panel setup. Size of gap varies due to glass tolerances.)

1. Standard thumb turn or optional keyed lock.
2. Footbolt
3. A clear anodized aluminum vertical tube push/pull handle, one on each side, is optional with the pivot panel closure.

4. Optional push bar, one side only (vertical bar will be on the opposite side).
5. Low profile push/pull handle supplies with every pivot panel.
6. Pivot block (floor)

World headquarters:

Hufcor Inc.
 P.O. Box 591
 Janesville, WI USA 53547
 1-800-542-2371 ext. 214; 1-608-756-1241
 FAX: 1-608-758-8253
 E-mail: info@hufcor.com
 Website: www.hufcor.com

The manufacturer reserves the right to improve and change product without notice.

Select Hufcor products are also manufactured in the U.S. at:
 Hufcor/Airwall, Inc., 8739 E. Artesia Blvd., Bellflower, CA 90707
 1-562-634-3116 FAX 1-562-630-8203