

UNISPAN SELF SUPPORT SYSTEM

Series U900 Unispan For use with Operable Partitions

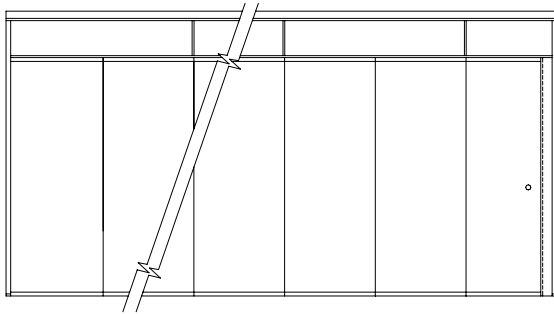

Approximate Maximum Opening Width to: 39'9" [12.09m]
Approximate Maximum Height to: 12'2" [3.7m]
Approximate Maximum Partition Height to: 10'2" [3.1m]
Maximum widths and heights are determined by the weight of the partition used in the Unispan. Contact your Hufcor Representative for special requirements.

PART 1 - GENERAL

1.01 DESCRIPTION

A. General

1. Furnish and install self-support truss system for use with operable partitions.

1.02 RELATED WORK BY OTHERS

- A. Preparation of opening will be by General Contractor. Any deviation of site conditions contrary to approved shop drawings must be called to the attention of the architect.
- B. All header, blocking, lateral bracing, surrounding insulation, and sound baffles as required in 1.04 Quality Assurance.
- C. Paint or otherwise finishing all trim and other materials adjoining the Unispan.

1.03 SUBMITTALS

- A. Complete shop drawings are to be provided prior to fabrication indicating construction and installation details. Shop drawings must be submitted within 60 days after receipt of signed contract.

1.04 QUALITY ASSURANCE

- A. Preparation of the opening shall conform to the criteria set forth per ASTM E557 Standard Practice for Architectural Application and Installation of Operable Partitions.
- B. The Unispan system shall be validated by calculations performed by a licensed Professional Engineer.

1.05 PRODUCT DELIVERY, STORAGE, AND HANDLING

- A. Proper storage of Unispan system before installation and continued protection during and after installation will be the responsibility of the General Contractor.

1.06 WARRANTY

- A. Partition system shall be guaranteed for a period of two years against defects in material and workmanship, excluding abuse.

PART 2 - PRODUCTS

2.01 ACCEPTABLE MANUFACTURERS

- A. Upon compliance with all of the criteria specified in this section, Manufacturers wishing to bid products equal to the product specified must submit to the architect 10 days prior to bidding complete data in support of compliance and a list of three past installations of products similar to those listed. The submitting manufacturer guarantees the proposed substituted product complies with the performance items specified and as detailed on the drawings.

2.02 MATERIALS

- A. Product to be Hufcor Series U900 Unispan as manufactured by Hufcor Inc.
 1. The supporting truss shall be factory fabricated of steel and aluminum. Unispan is attached to the building structure for lateral support only. The load of the truss and partition is supported by the Unispan column posts.

PRODUCT OVERVIEW:

The Unispan self-support system allows the use of paired or individual partitions in buildings with inadequate support to accommodate the hanging weight of operable partitions.

Consisting of a horizontal truss and two support columns, the system attaches to the building for lateral support only. It can be relocated if the owner wishes to reconfigure the space in the future.

The truss accommodates sound baffle panels and insulation for areas requiring sound control.

Bolt together truss has anodized aluminum top and bottom chords with integral anodized aluminum track and steel web-members.

2. Posts. End columns shall be 2-1/2" x 5" [63.5 x 127] clear anodized aluminum posts. Posts shall be attached to the truss with steel brackets and bolts. Posts shall be anchored to the floor with concealed fasteners. Posts shall be located approximately 1-1/2" [38] from adjacent wall surfaces. The space between the post and the adjacent wall shall be fitted with a vinyl gasket to inhibit sound.
3. Ceiling anchors provide lateral support and shall be set at intervals across the span of the beam. Blocking for ceiling anchors to be provided by others in accordance with the plans.

B. Weight of the system

1. The horizontal truss shall weigh 10-12 lbs. per lineal foot of width.
2. The support columns shall weigh 3.5 lbs. per foot of height each.
3. The floor shall support a maximum of 360 psi at each post.

C. Finishes

1. Exposed trim and track shall be of clear anodized architectural grade extruded aluminum alloy 6063-T6.
 2. Posts shall be of clear anodized architectural grade extruded aluminum alloy 6063-T6.
- D. Available Accessories/Options
1. Medium Density Fiberboard Header Side Panels (to cover sides of truss if it is below the ceiling).
 - a. Vinyl covered. Color to be selected from partition manufacturer's standard line.
 - b. Carpet covered. Color to be selected from partition manufacturer's standard line.
 - c. Fabric covered. Color to be selected from partition manufacturer's standard line.
 - d. Unfinished for field finishing.
 - e. Mineral wool insulation for sound retardation.
 - f. The truss may be shipped in sections and assembled on site for use in areas with limited access.

2.03 OPERATION

- A. Operable partitions installed in the Unispan system shall be manually operated.
- B. Unispan may be disassembled and relocated to an alternate location as needed.

PART 3 - EXECUTION

A. Installation.

The complete installation of the Unispan self-support system shall be by an authorized factory-trained installer and be in strict accordance with the approved shop drawings and manufacturer's standard printed specifications, instructions, and recommendations.

B. Cleaning

1. All surfaces shall be wiped clean and free of handprints, grease, and soil.
2. Cartoning and other installation debris shall be removed from the job site.



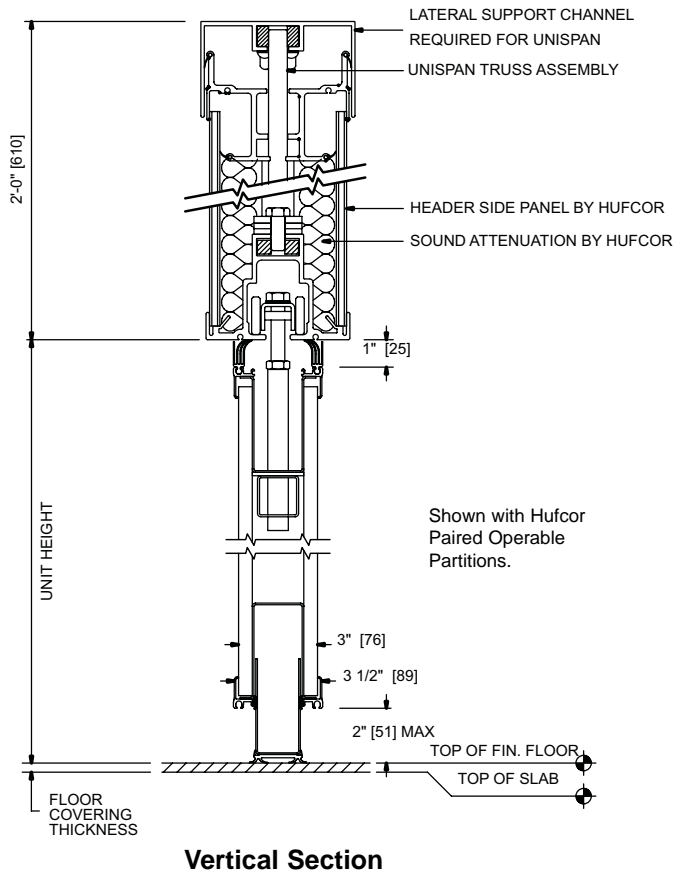

Option below: Horizontal truss partially exposed below lay-in ceiling.

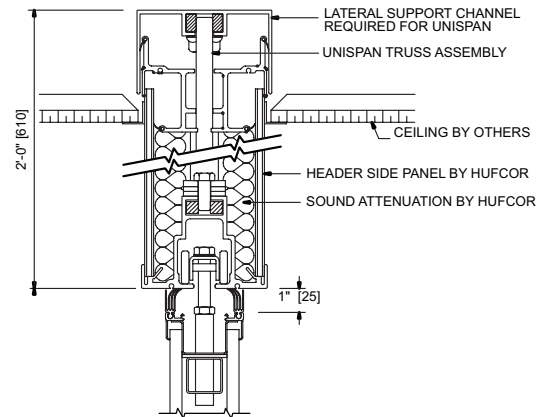

Horizontal Section

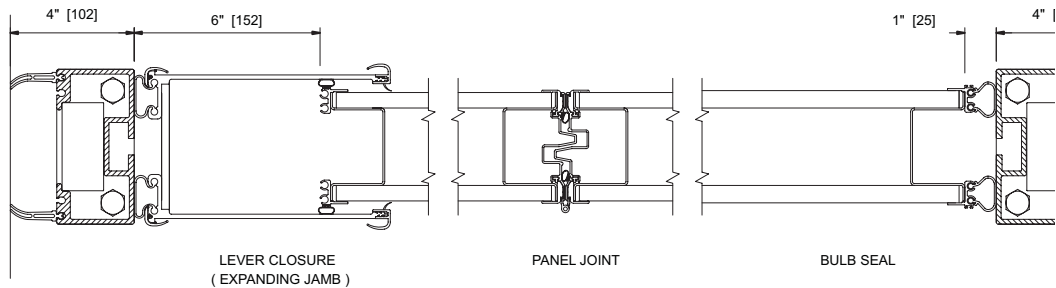

Stack Size: To determine the stack depth, refer to the specifications for the operable partition model used in the Unispan. Remember to also add 4" [102] for the support column (a/k/a post).

Worldwide headquarters:

Hufcor Inc.
P.O. Box 591
Janesville, WI USA 53547
1-800-542-2371 ext. 214; 1-608-756-1241
FAX: 1-608-758-8253
E-mail: info@hufcor.com
Website: www.hufcor.com

Not to Scale

The manufacturer reserves the right to improve and change product without notice.